

TYPICAL FLAT WALL PANEL CROSS SECTION

NOTE:

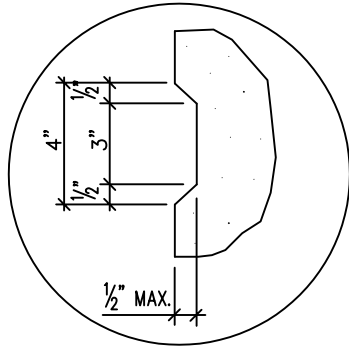

SECTION A-A
TYPICAL REVEAL

	A	B	C
1'-0" THICK		3 1/2"	5"
10" THICK		3 1/2"	3"
8" THICK		3"	2"

INTERIOR FACE
FINISH: SMOOTH FLOAT

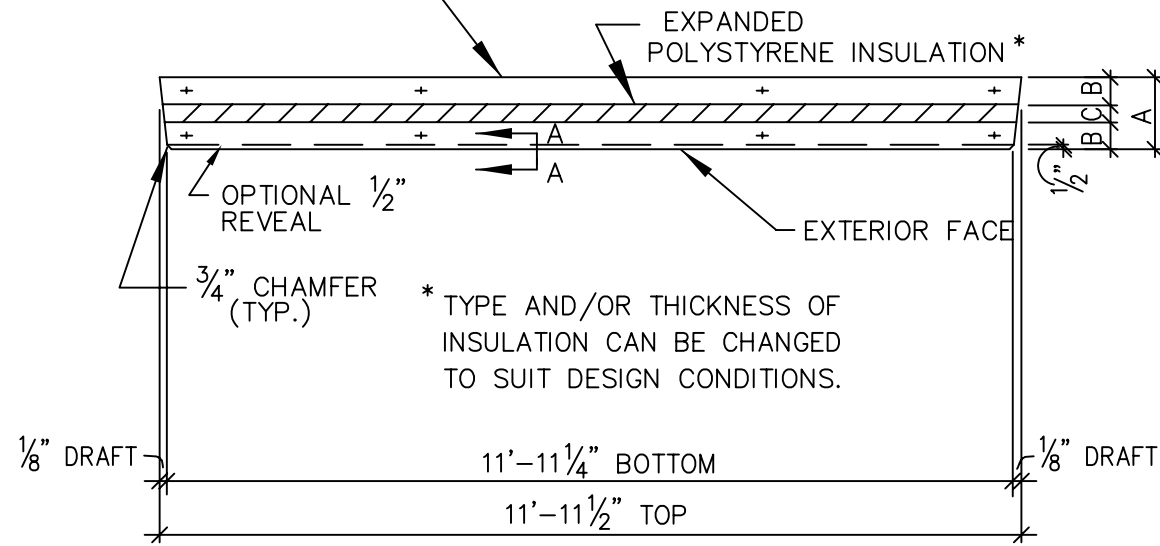

12'-0" INSULATED FLAT PANEL

WEIGHT @ 78 lbs/sq. ft.

8'-0", 10'-0" & 15'-0" PANELS ARE ALSO AVAILABLE

REVISIONS:

DATE:

APPROVED FOR PRODUCTION:

FILE NAME:

DR:

DATE:

DPS-1

CK:

JOB NO.: